

THIS DRAWING IS UNPUBLISHED. RELEASED FOR PUBLICATION
 © COPYRIGHT BY TYCO ELECTRONICS CORPORATION. ALL RIGHTS RESERVED.

LOC		DIST		REVISIONS			
P	LTR	DESCRIPTION	DATE	DWN	APVD		
AF	50	B	REV PER ECR -06-010492	02OCT06	JR	KR	

- 1 CONTINUOUS STRIP ON REELS WITH TERMINALS LOCATED ON 8.38±0.08 [.330±.003] CENTERS.
- 2 SLOT TERMINATES A SINGLE COPPER MAGNET WIRE COPPER RANGE: 0.91-1.13mm [#19-#17] AWG.

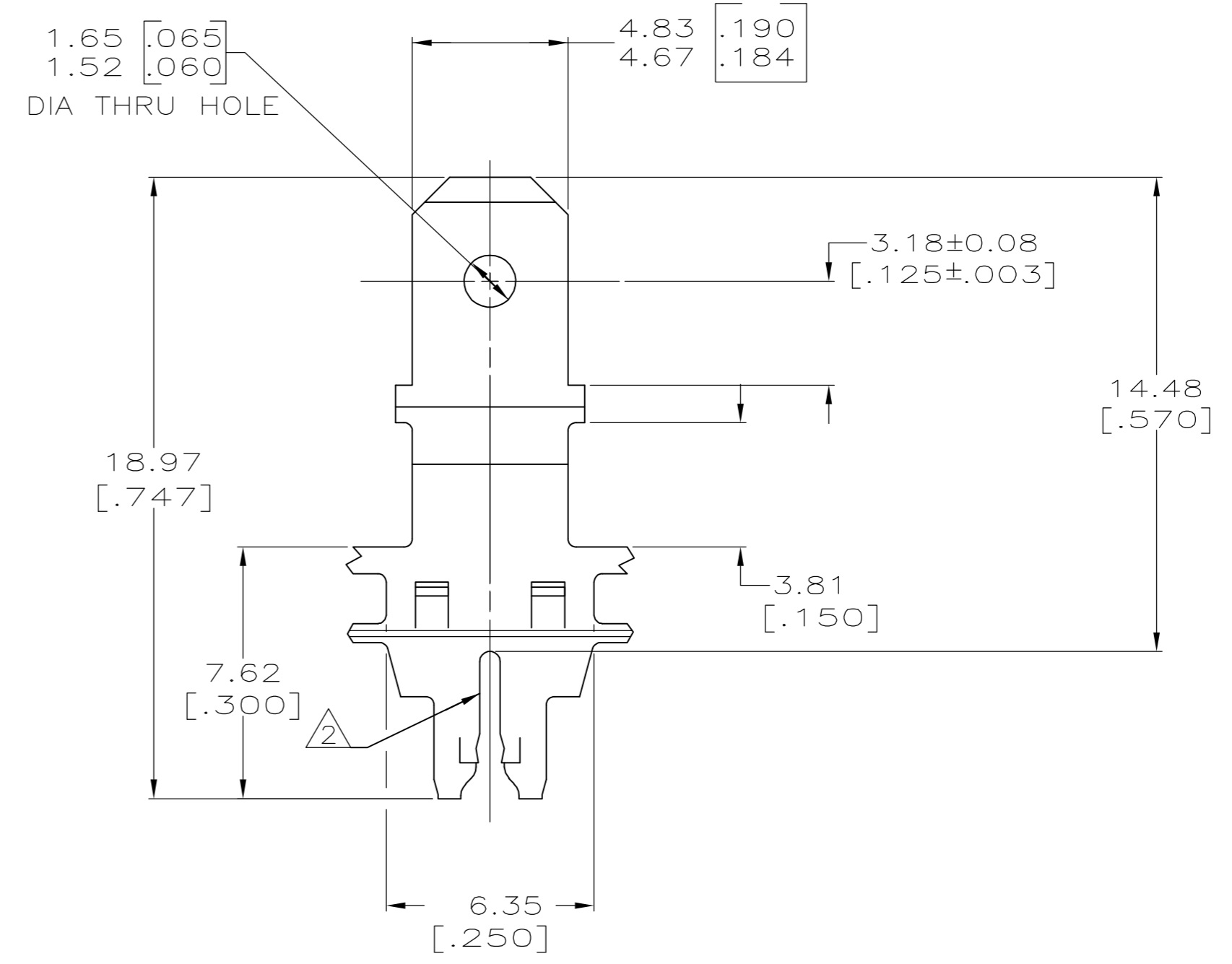
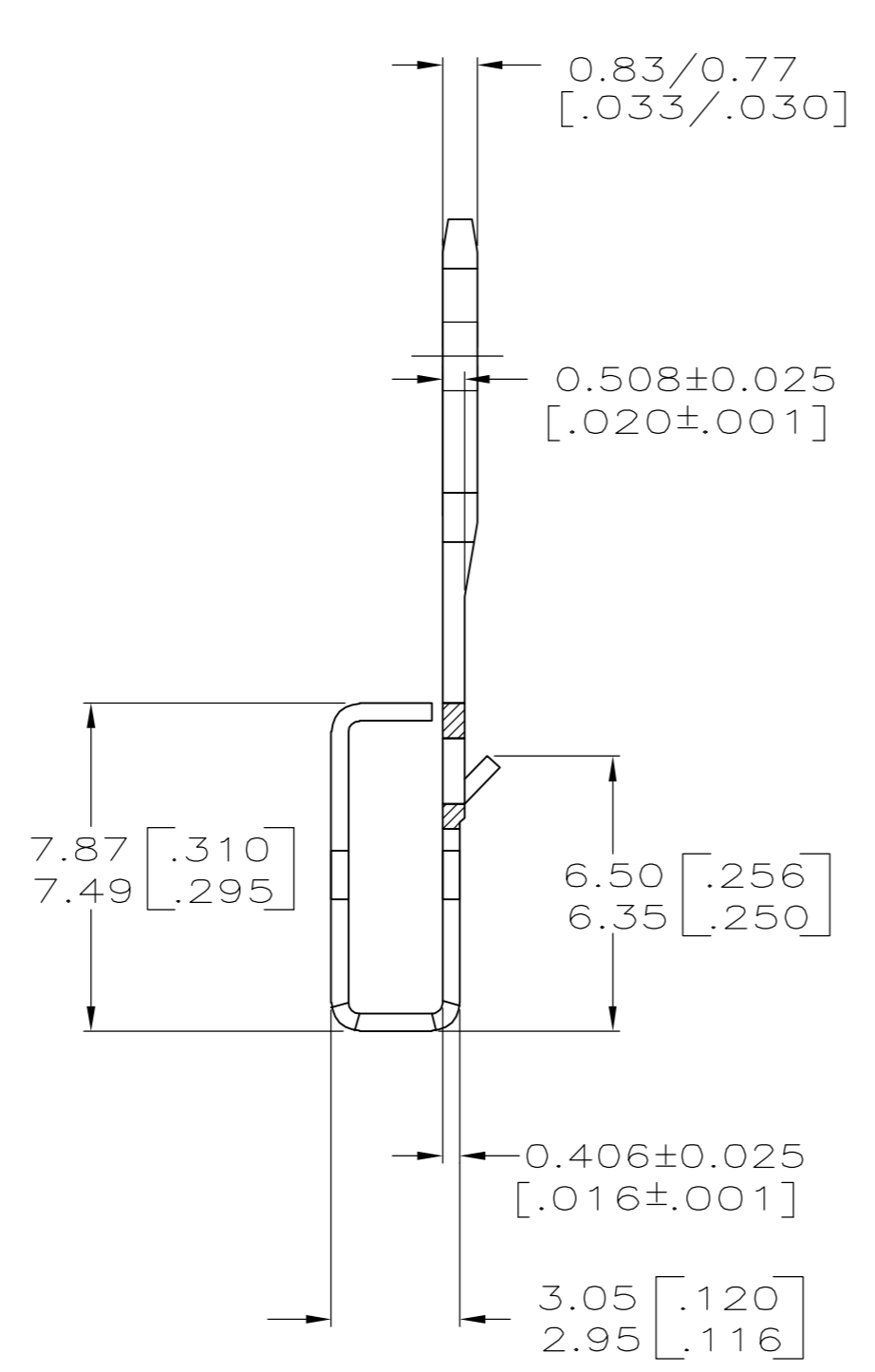
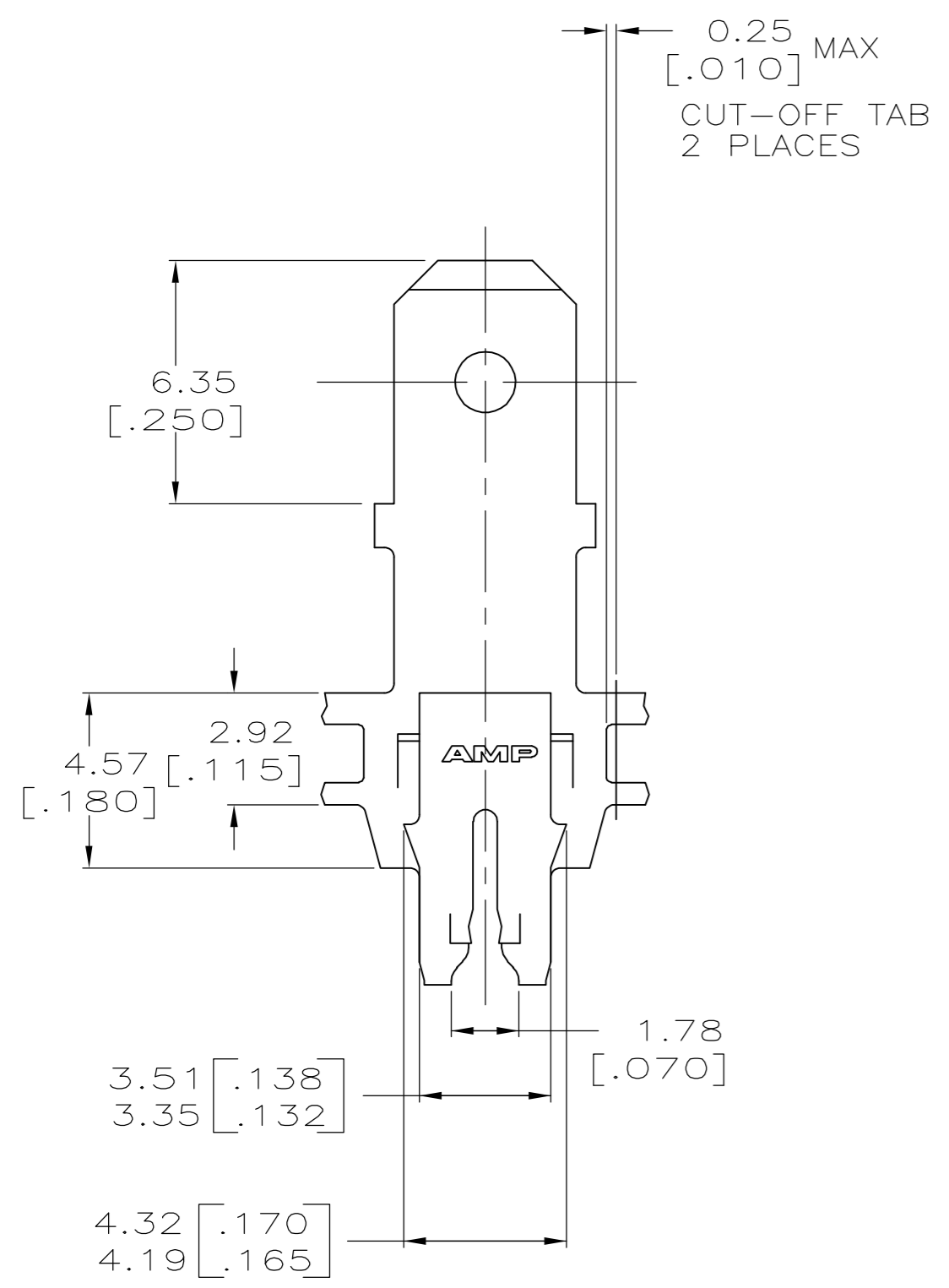
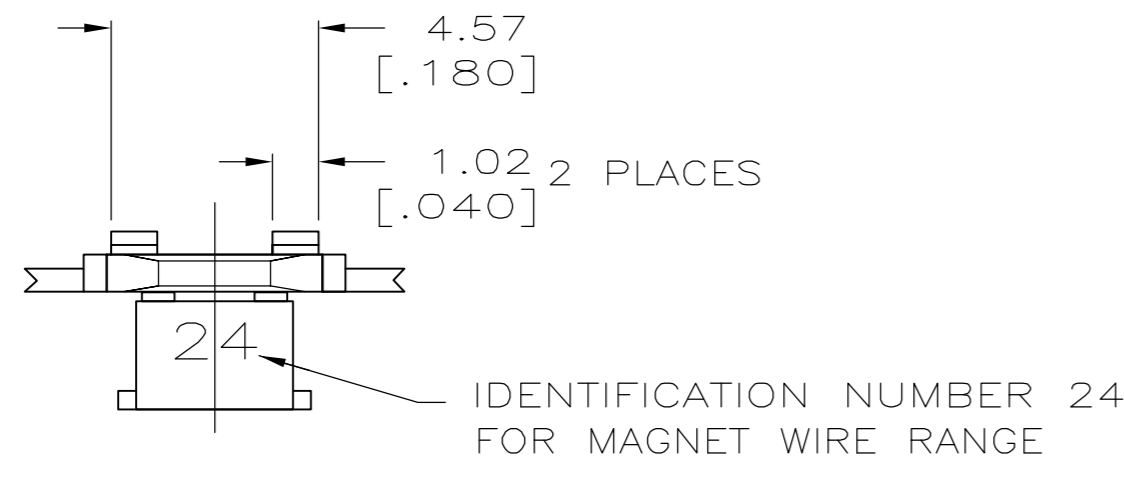

1217994-1
 PART NUMBER

THIS DRAWING IS A CONTROLLED DOCUMENT.		DWN 02OCT2003 MICHAEL S. FEHER	Tyco Electronics Corporation Harrisburg, PA 17105-3608	
DIMENSIONS: mm [INCHES]		CHK 02OCT2003 KURT A. RANDOLPH		
TOLERANCES UNLESS OTHERWISE SPECIFIED:		APVD 02OCT2003 KURT A. RANDOLPH	NAME TAB, 4.75 [.187] FASTON,™ 300 SERIES MAG-MATE™	
0 PLC ± - 1 PLC ± - 2 PLC ± 0.25 [.010] 3 PLC ± - 4 PLC ± - ANGLES ± -		PRODUCT SPEC 108-2012	SIZE A2	CAGE CODE 00779
MATERIAL 4M PRE-MILLED BRASS		FINISH 0.002032 [.000080] MIN TIN PLATE	APPLICATION SPEC 114-2094	DRAWING NO C=1217994
		WEIGHT -	RESTRICTED TO -	SCALE 6:1
		CUSTOMER DRAWING	SHEET 1	OF 1
			REV B	