

LOC	DIST	REVISIONS					
GP	0	F	LTR	DESCRIPTION	DATE	DWN	APVD
		0		RELEASED PER 0515-0339-03	26NOV03	JB	CF

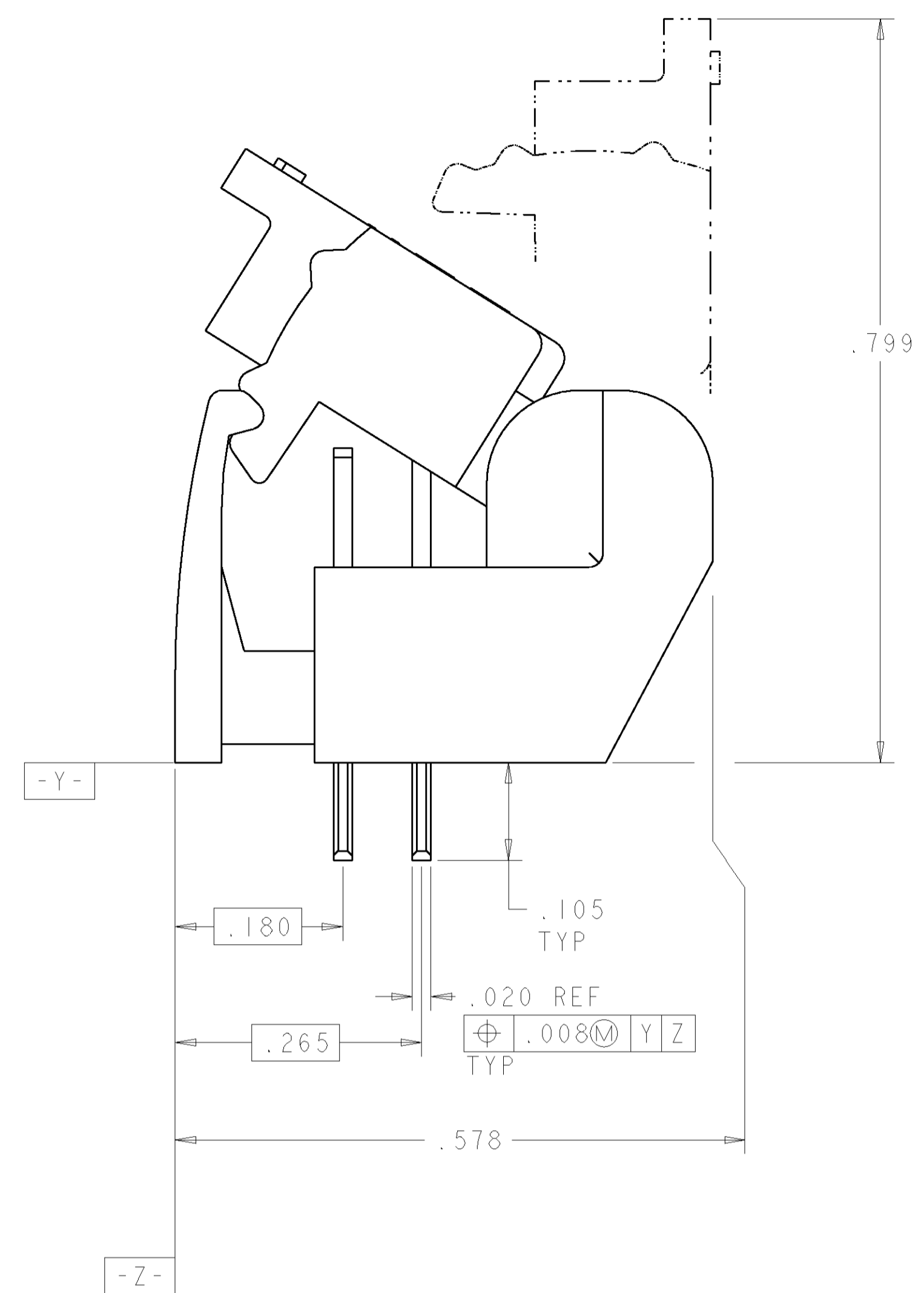

- 1 MATERIAL: BASE - POLYESTER MOLDING COMPOUND, BLACK.  
WIRE STUFFER: - POLYESTER MOLDING COMPOUND, SEE TABLE FOR COLOR.  
TERMINAL - COPPER ALLOY, PLATED WITH 3.81µm MINIMUM THICK TIN-LEAD OVER 1.27µm MINIMUM THICK NICKEL UNDERPLATE.
- 2 EACH WIRE ENTRY HOLE ACCEPTS ONE UNSTRIPPED SOLID COPPER 22-26 AWG WIRE WITH WIRE INSULATION DIAMETER RANGE FROM .060 THROUGH .040. OTHER WIRE SIZES AND TYPES SHALL BE SUBMITTED TO AMP ENGINEERS FOR APPLICATION APPROVAL.
- 3. SOLDER TABS PROVIDED FOR PERMANENT BOARD MOUNTING.
- 4 LOCATION OF HOLE PATTERN DETERMINED BASED ON CUSTOMER REQUIREMENTS.

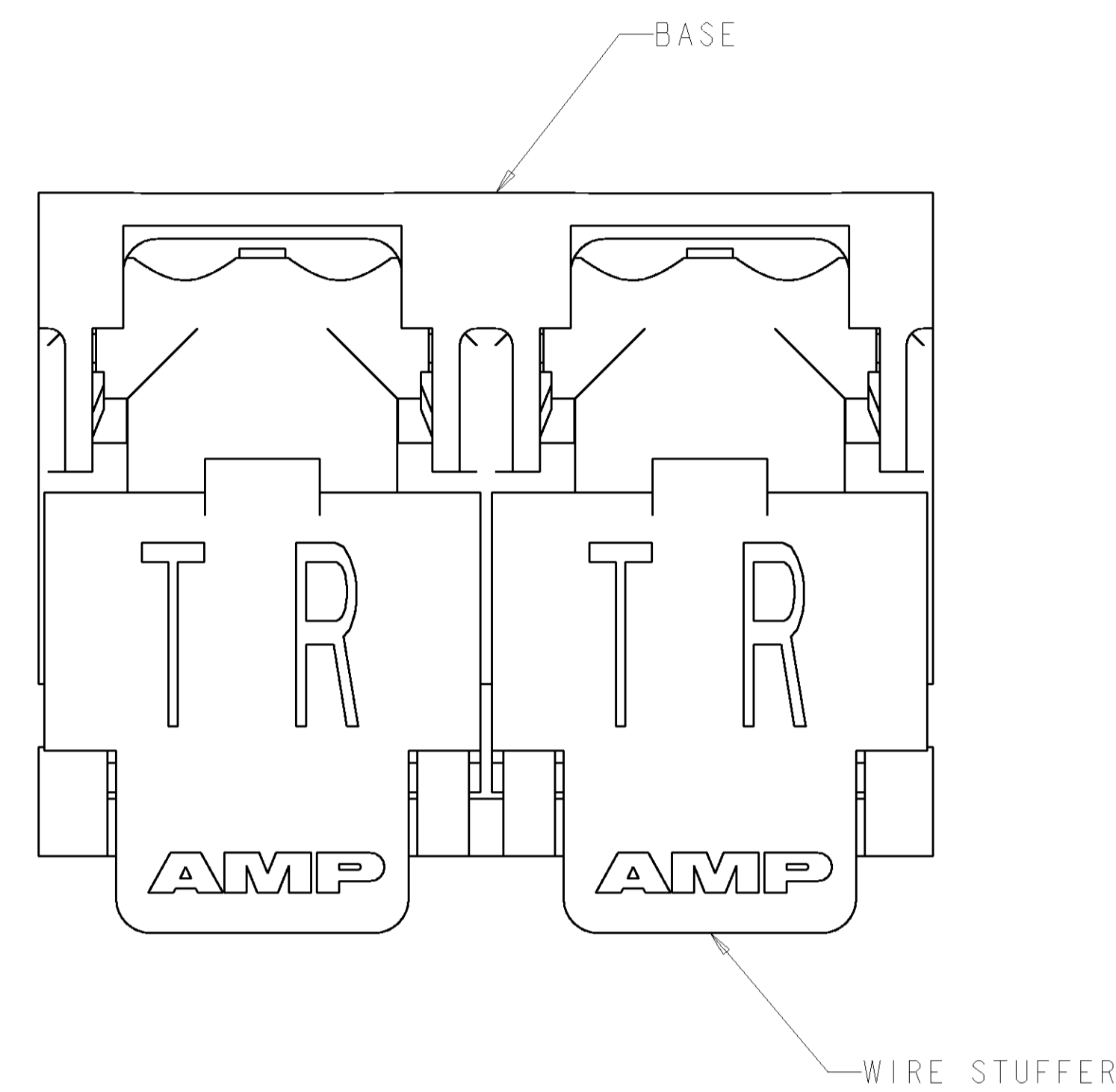
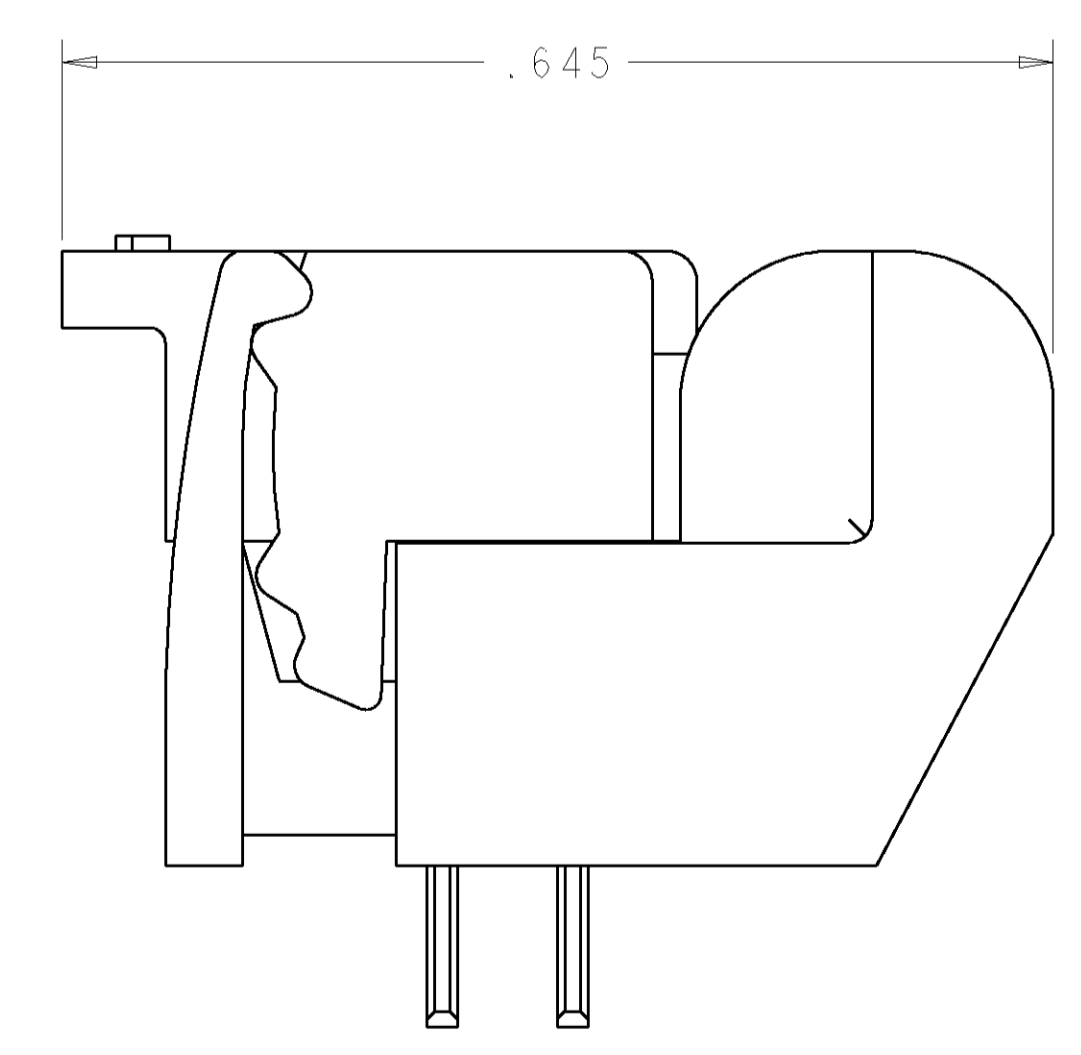
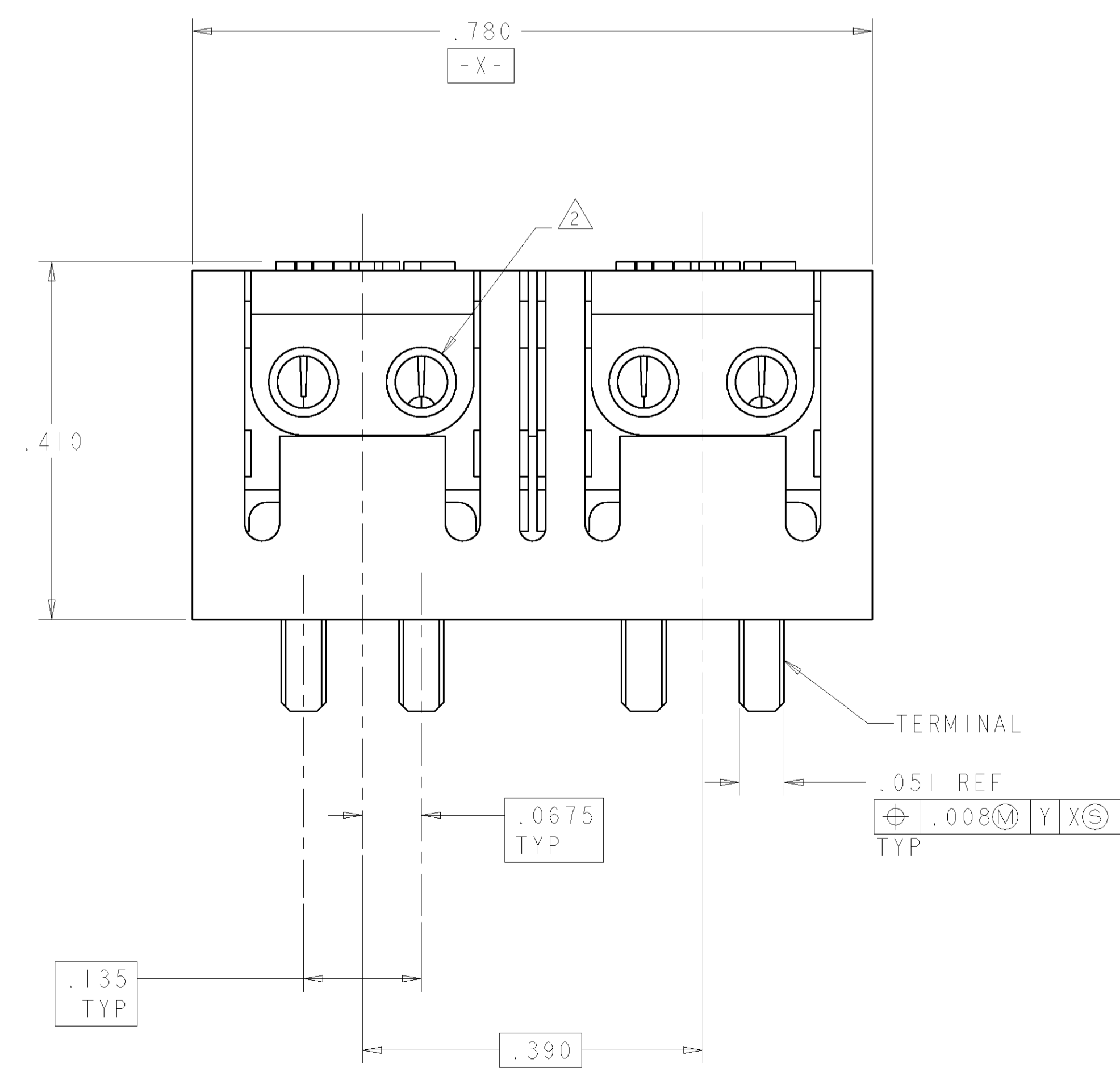

CLOSED POSITION

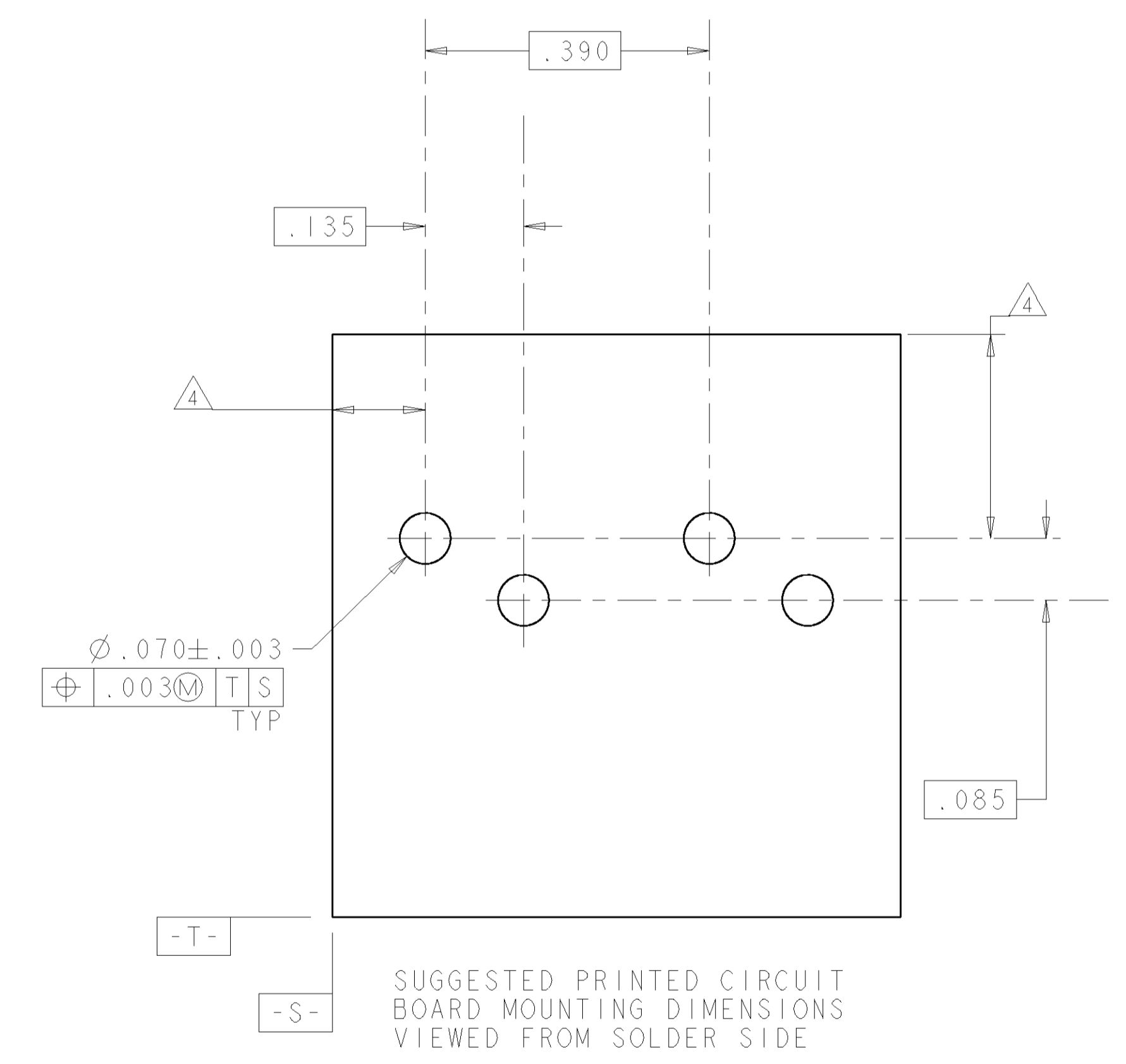

SUGGESTED PRINTED CIRCUIT BOARD MOUNTING DIMENSIONS VIEWED FROM SOLDER SIDE

RED	GREEN	CLEAR	1658921-1
R	T	WIRE STUFFER	PART NUMBER
COLOR CODE			

<small>THIS DRAWING IS UNPUBLISHED. RELEASED FOR PUBLICATION. ALL RIGHTS RESERVED.</small>		DWN	J. BURWELL	26NOV03	AMP Incorporated Harrisburg, PA 17105-3608
<small>ALL DIMENSIONS ARE IN INCHES UNLESS OTHERWISE SPECIFIED.</small>		CHK	C. FULLER	26NOV03	
DIMENSIONS:	TOLERANCES UNLESS OTHERWISE SPECIFIED:	NAME		ASSEMBLY, DOUBLE PAIR, DOUBLE ENTRY, PIVOT II CONNECTOR	
INCHES	0 PLC ± 1 PLC ±.01 2 PLC ±.01 3 PLC ±.005 4 PLC ± ANGLES ±	PRODUCT SPEC			
		APPLICATION SPEC			
MATERIAL	FINISH	WEIGHT	SIZE	CAGE CODE	DRAWING NO.
			A1	00779	C=1658921
CUSTOMER DRAWING		SCALE	6:1	SHEET	1 OF 1