

## CO2 Gas Sensor Module (#27929)

The CO2 Gas Sensor Module is designed to allow a microcontroller to determine when a preset Carbon Dioxide gas level has been reached or exceeded. Interfacing with this sensor is done through a 4-pin SIP header and requires two I/O pins from the host microcontroller. The sensor module is intended to provide a means of comparing gas sources and being able to set an alarm limit when the source becomes excessive. **Parallax does not provide gas calibration data on this module and such data as well as the alarm settings are the responsibility of the user to define. For information on calibration please see page 3.**

### Features

- Easy SIP header interface
- Compatible with most microcontrollers
- Low-power standby mode

### Application Ideas

- Gas level over-limit alarm
- Stand-alone/background sensing device
- Environmental monitoring equipment

### Key Specifications

- Power requirements: 6.5 – 12 VDC @ ~165 mA (heater on) / ~1.2 mA (heater off)
- Interface: 1 TTL compatible input (CNTL), 1 TTL compatible output (ALR)
- Operating temperature: 32°F to 158°F (0°C to 70°C)
- Dimensions: 1.50" x 1.00" x 1.00" (38.1 mm x 25.4 mm x 25.4 mm)

### Packing List

- Gas Sensor
- Gas Sensor PCB Assembly
- Potentiometer adjustment tool

### Precautions

**Be aware that the gas detected by this gas sensor can be deadly in high concentrations. 1% (10,000 ppm) will make some people feel drowsy. Concentrations of 7% to 10% can cause dizziness, headache, visual and hearing dysfunction and unconsciousness within a few minutes to an hour. Always be careful to perform gas tests in well-ventilated areas.**

THIS GAS SENSOR MODULE IS NOT DESIGNED FOR OR APPROVED FOR ANY APPLICATION INVOLVING HEALTH OR HUMAN SAFETY. THIS GAS SENSOR MODULE IS FOR EXPERIMENTAL PURPOSES ONLY. PARALLAX, INC. ABSOLVES ITSELF OF ALL LIABILITY AND RESPONSIBILITY ASSOCIATED WITH THE CUSTOMER'S USE OF THIS GAS SENSOR MODULE AND IS NOT RESPONSIBLE FOR ANY BODILY INJURY, DEATH OR PROPERTY DAMAGE AS A RESULT OF USING THIS GAS SENSOR MODULE.

IMPORTANT: CO2 SENSORS ARE POLARIZED. SENSORS FROM THE FACTORY HAVE A RED DOT ON ONE SIDE. WHEN INSERTING THE SENSOR INTO THE SOCKET ON THE MODULE THE RED DOT MUST BE TO THE LEFT IF YOU'RE LOOKING AT THE FRONT OF THE MODULE WITH THE PINS DOWN. FAILURE TO FOLLOW THIS WILL CAUSE THE SENSOR TO MALFUNCTION AND PREVENT CALIBRATION.

## Connecting and Testing

The 4-pin SIP header on the Gas Sensor Module makes it easy to connect to a breadboard or SIP socket. The four connections are defined in the table below. Connection to a microcontroller, such as the BASIC Stamp® module or Propeller chip, is pretty straight forward and requires two I/O pins; one input for detecting the alarm signal and another output for controlling the internal heater.

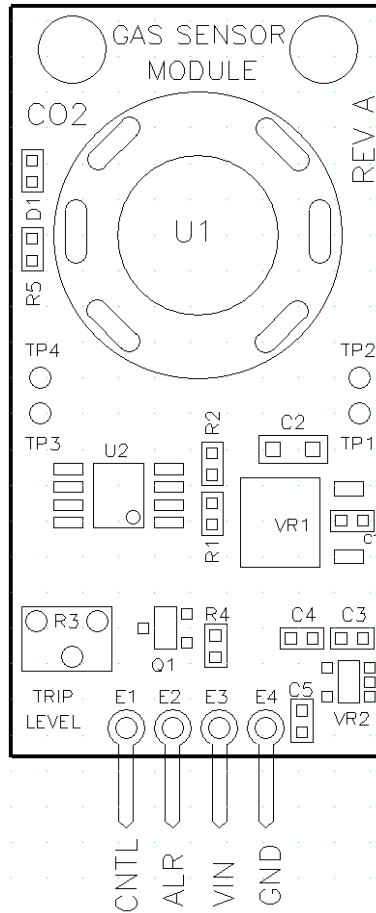

## Pin Definitions and Ratings

Pin	Name	Function	Level
E1	CNTL	Heat switch input from microcontroller, active HIGH	0V – 12VDC
E2	ALM	Alarm output to host microcontroller, active HIGH	0V / 3.3V
E3	VIN	Input voltage	+6.5 – 12VDC
E4	GND	Ground, connects to common ground	0V
TP1	Test Point 1+	Buffered output of sensor (buffer/amplifier)	0V – 3.35V
TP2	Test Point 2-	Ground, connects to common ground	0V
TP3	Test Point 3+	Trip Level voltage set by potentiometer (R3)	0V – 3.3V
TP4	Test Point 4-	Ground, connects to common ground	0V

\* The CNTL line is internally pulled down to 0V via a 150 kΩ resistor.

NOTE: Sensor may rattle if shaken – this is normal.

## Theory of Operation

The CO<sub>2</sub> gas sensor module uses a gas sensor (MG811) from Hanwei Electronics. When the internal heating element is activated, this gas sensor responds to CO<sub>2</sub> gas by generating a small voltage in proportion to the amount of CO<sub>2</sub> gas present in the air exposed to the internal element. The sensor is a high impedance device and requires a buffer/amplifier to measure the output. The output from the buffer/amplifier (op-amp) is then sent to the inverting input of another op-amp in the same package (LMC6035) which is configured as a comparator. A voltage divider formed by R3 is used to provide a reference voltage. The output of this voltage divider is fed into the non-inverting inputs of the second op-amp on the LMC6035 dual op-amp IC. The buffered output of the sensor can be measured for the signal voltage at TP1 (+) and TP2 (-). The reference voltage is available at TP3 (+) and TP4 (-).

The output of op-amp B goes out to the ALR pin through a 1 k $\Omega$  resistor providing a TTL-compatible signal to a microcontroller. This output also connects to a red LED on the gas sensor module. The trip level adjustment is set via potentiometer R3. This is just a simple voltage divider that lets you set the voltage from 0V to 3.3V. This voltage is compared to the voltage coming from the gas sensor buffer/op-amp. When the voltage from the gas sensor is lower than the voltage set by potentiometer R3 the red LED will light and the ALR output will be high (3.3 V). The voltage from the sensor actually drops as CO<sub>2</sub> increases. The section below describes how to configure these gas sensor modules to detect gas with minimal calibration.

## Calibration

The procedure for setting the potentiometer is explained below. Please note that turning the potentiometer clockwise decreases voltage, while turning the potentiometer counter-clockwise increases it. This can be compared to a water valve.

- Place the Gas Sensor Module in a clean air environment and supply power to the module. The heater should be active during this time. Allow at least 5 minutes before making adjustments.
- Measure the voltage at TP1 (+) and TP2 (-). It should be between 1.5 – 2V, but could be from 1V – 3.3V.
- Adjust potentiometer R3 (Trip Level) until the voltage across TP3 (+) and TP4 (-) reads approximately just below the reading from TP1/TP2. The LED should go out.
- Apply your gas source to the gas sensor. The LED should light up.
- Remove the gas source and allow the sensor to settle. The LED should go back out.
- If the LED does not go out within 60 seconds, adjust R3 until the LED goes out and repeat the two previous steps.

The gas sensor module's ALR pin should only be checked when the heater is on and the readings have stabilized.

## Sources of Gas for Calibration / Testing

Your breath contains CO<sub>2</sub> gas when you exhale. However you also have to be aware that contaminants can affect the calibration of the sensor. Your breath also contains moisture and potentially other particulates. Breathing briefly on the sensor with a single breath is a convenient way to see it react to CO<sub>2</sub>.

## Resources and Downloads

You may download the manufacturer datasheet, etc. from the gas sensor product page on our website by browsing to <http://www.parallax.com> and typing 27929 into our search box and clicking, "GO".

# Module Schematic

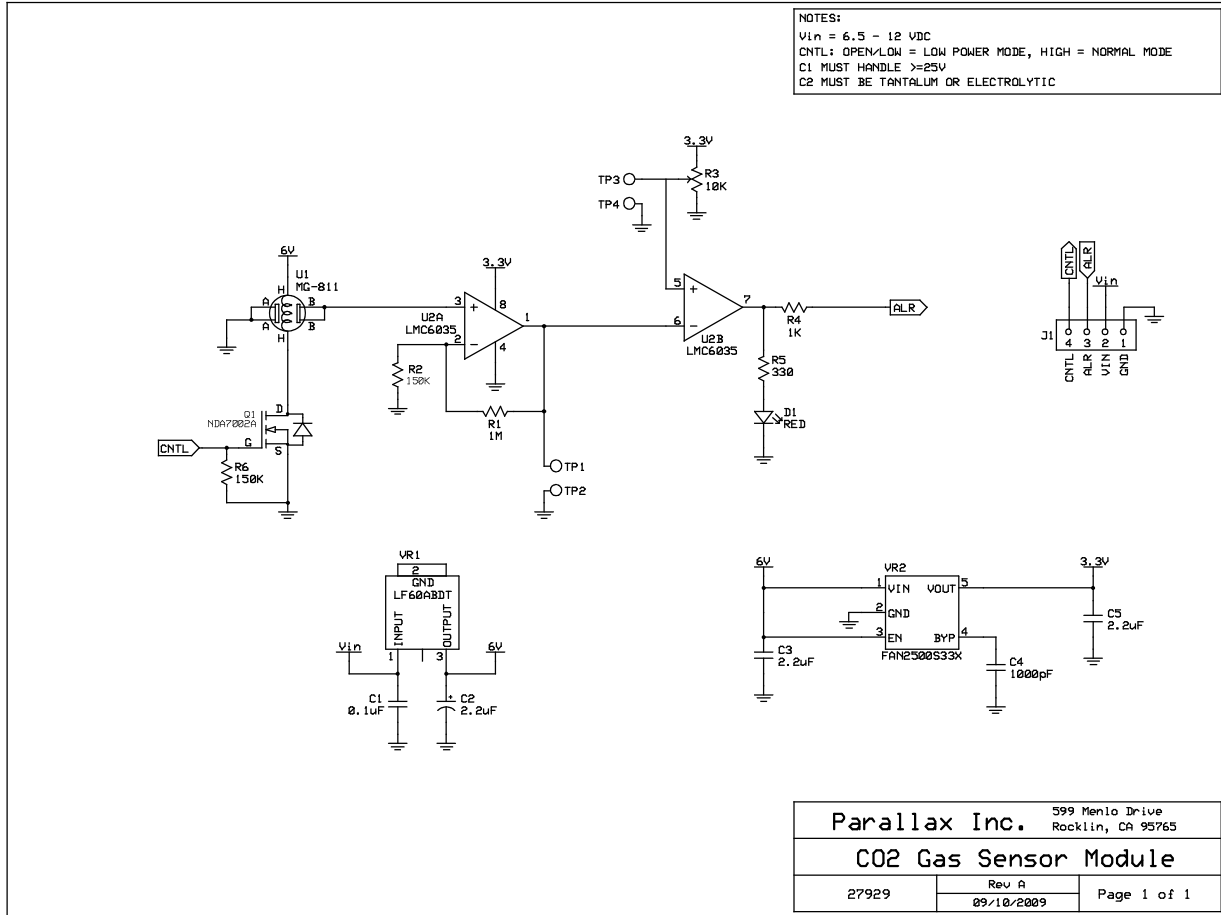

Parallax Inc.		599 Menlo Drive Rocklin, CA 95765
<b>CO2 Gas Sensor Module</b>		
27929	Rev A 09/10/2009	Page 1 of 1